

Überauszug Serie DDTS-48

Over extension series DDTS-48

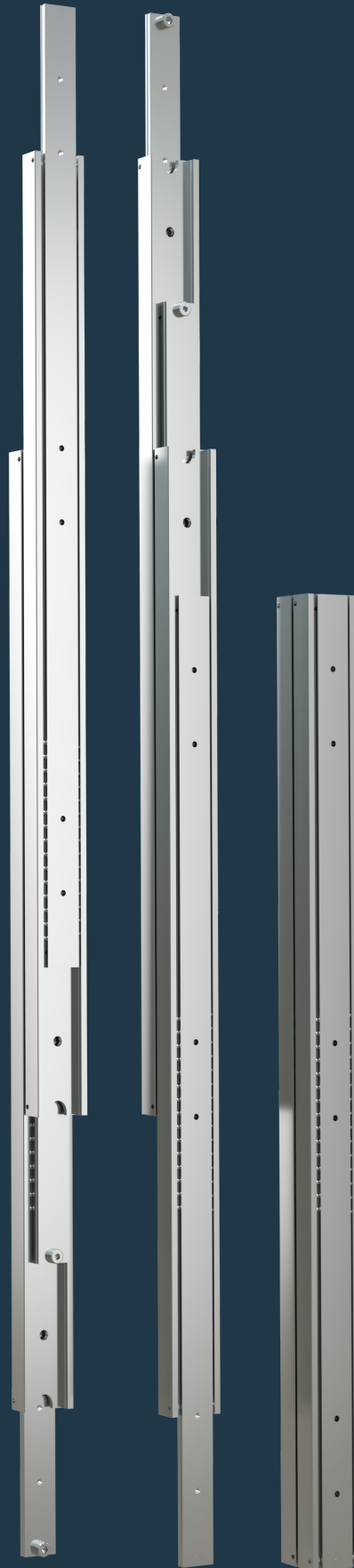

- Tragkraft bis zu 90 kg
- Auszugsweg 100% +

Werkstoffe und Oberflächen:

- Schienen: Kaltgewalzter Kohlenstoffstahl C45E+C, - EN 10277, gefräste Laufbahnen.
- Kugelkäfige: Verzinktes Stahlblech
- Kugeln: Verchromt C85 G100: DIN 5401

Temperaturbereich:

- Einsatztemperatur -40°C bis +200°C

- Load capacity up to 90 kg
- Extension path 100% +

Materials and surfaces:

- Beams: Cold drawn carbon steel C45E+C, - EN 10277, milled raceways.
- Ball cage: Zinc plated sheet steel
- Ball bearings: Chromed C85,G100: DIN 5401
- End Bolts: ASTM A307

Temperature range:

- Operating temperature -40°C to +200°C



DDTS-48

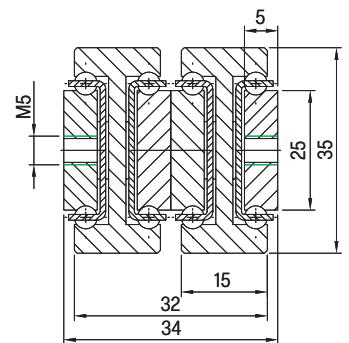
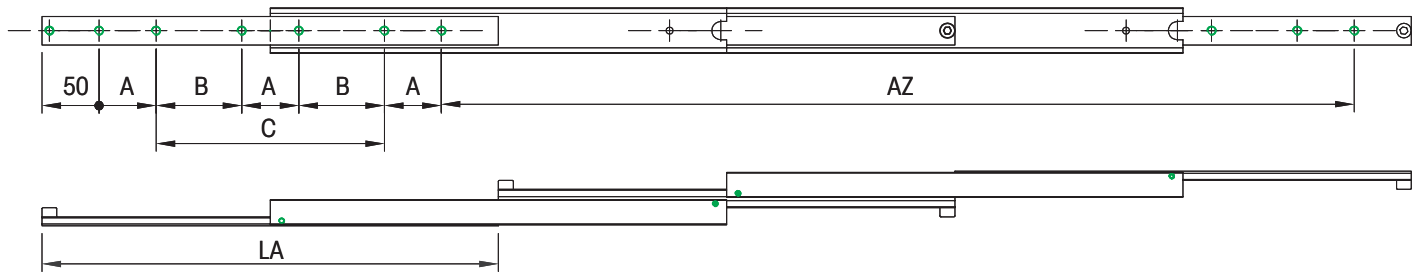

Artikel-Nr. SToxxparts	LA mm	AZ mm	TK in kg 10.000	A mm	B mm	C mm	Gewicht weight kg/St. kg/pcs.
07000477001	150	300	70	50	-	-	1,25
07000477002	200	400	75	50	-	-	1,65
07000477003	250	500	80	50	-	50	2,05
07000476004	300	600	85	50	-	100	2,46
07000477005	350	700	90	50	-	150	2,86
07000477006	400	800	85	50	-	200	3,26
07000477007	450	900	80	50	-	250	3,67
07000477008	500	1000	75	50	-	300	4,07
07000477009	550	1100	70	50	150	-	4,47
07000477010	600	1200	65	50	175	-	4,88
07000477011	650	1300	60	50	200	-	5,28
07000477012	700	1400	55	50	225	-	5,68
07000477013	750	1500	50	50	250	-	6,09
07000477014	800	1600	45	50	275	-	6,49
07000477015	850	1700	40	50	300	-	6,89
07000477016	900	1800	35	50	325	-	7,30
07000477017	950	1900	30	50	350	-	7,70
07000477018	1000	2000	20	50	375	-	8,10

Hinweise | Notes:

LA = Länge | Length, AZ = Auszugsweg | Move-out path, TK = Tragkraft | Load capacity |

 Bohrbild / Hole pattern

Die Tragfähigkeit im horizontalem Einbau reduziert sich um 60-80%.

Flat mounted slide load capacities are reduced between 60-80%