

# Überauszug Serie DDTS-40

Over extension series DDTS-40



- Tragkraft bis zu 160 kg
- Auszugsweg 100% +

#### Werkstoffe und Oberflächen:

- Schienen: Kaltgewalzter Kohlenstoffstahl C45E+C, - EN 10277, gefräste Laufbahnen.
- Kugelkäfige: Verzinktes Stahlblech
- Kugeln: Verchromt C85 G100: DIN 5401

#### Temperaturbereich:

- Einsatztemperatur -40°C bis +200°C

- Load capacity up to 160 kg
- Extension path 100% +

#### Materials and surfaces:

- Beams: Cold drawn carbon steel C45E+C, - EN 10277, milled raceways.
- Ball cage: Zinc plated sheet steel
- Ball bearings: Chromed C85,G100: DIN 5401
- End Bolts: ASTM A307

#### Temperature range:

- Operating temperature -40°C to +200°C

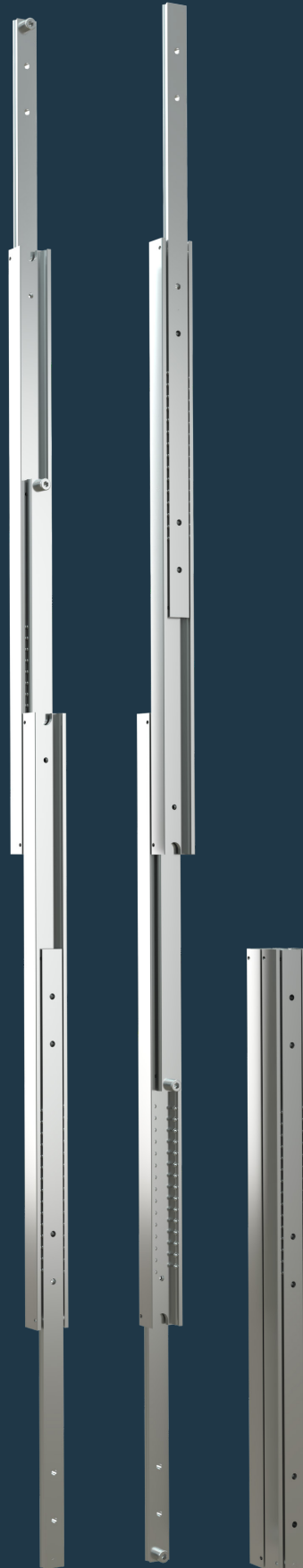

# DDTS-40

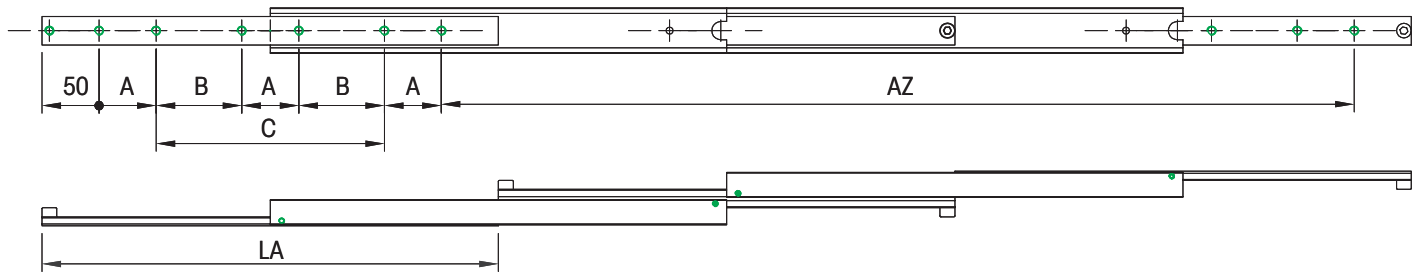

Artikel-Nr. SToxxparts	LA mm	AZ mm	TK in kg 10.000	A mm	B mm	C mm	Gewicht   weight kg/St.   kg/pcs.
07000475001	200	400	130	50	-	-	2,30
07000475002	250	500	138	50	-	50	2,86
07000475003	300	600	145	50	-	100	3,43
07000475004	350	700	152	50	-	150	3,99
07000475005	400	800	160	50	-	200	4,56
07000475006	450	900	155	50	-	250	5,12
07000475007	500	1000	150	50	-	300	5,69
07000475008	550	1100	145	50	150	-	6,25
07000475009	600	1200	140	50	175	-	6,82
07000475010	650	1300	135	50	200	-	7,38
07000475011	700	1400	130	50	225	-	7,95
07000475012	750	1500	125	50	250	-	8,52
07000475013	800	1600	120	50	275	-	9,08
07000475014	850	1700	115	50	300	-	9,65
07000475015	900	1800	110	50	325	-	10,21
07000475016	950	1900	105	50	350	-	10,78
07000475017	1000	2000	100	50	375	-	11,34
07000475018	1050	2100	95	50	400	-	11,91
07000475019	1100	2200	90	50	425	-	12,47
07000475020	1150	2300	85	50	450	-	13,04
07000475021	1200	2400	80	50	475	-	13,60

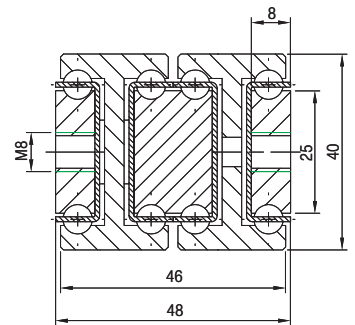

## Hinweise | Notes:

LA = Länge | Length, AZ = Auszugsweg | Move-out path, TK = Tragkraft | Load capacity |

 Bohrbild / Hole pattern

Die Tragfähigkeit im horizontalem Einbau reduziert sich um 60-80%.

Flat mounted slide load capacities are reduced between 60-80%