

Überauszug Serie DDTS-35

Over extension series DDTS-35



- Tragkraft bis zu 100 kg
- Auszugsweg 100% +

Werkstoffe und Oberflächen:

- Schienen: Kaltgewalzter Kohlenstoffstahl C45E+C, - EN 10277, gefräste Laufbahnen.
- Kugelkäfige: Verzinktes Stahlblech
- Kugeln: Verchromt C85 G100: DIN 5401

Temperaturbereich:

- Einsatztemperatur -40°C bis +200°C

- Load capacity up to 100 kg
- Extension path 100% +

Materials and surfaces:

- Beams: Cold drawn carbon steel C45E+C, - EN 10277, milled raceways.
- Ball cage: Zinc plated sheet steel
- Ball bearings: Chromed C85,G100: DIN 5401
- End Bolts: ASTM A307

Temperature range:

- Operating temperature -40°C to +200°C

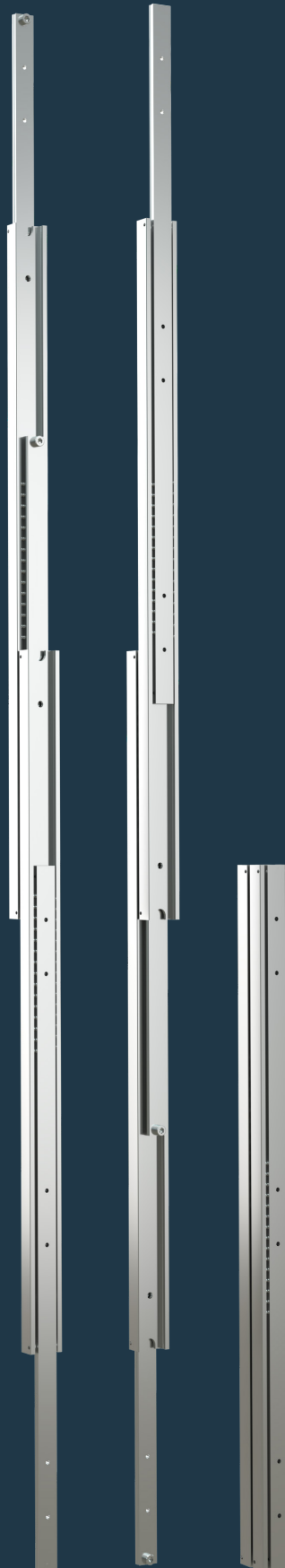

DDTS-35

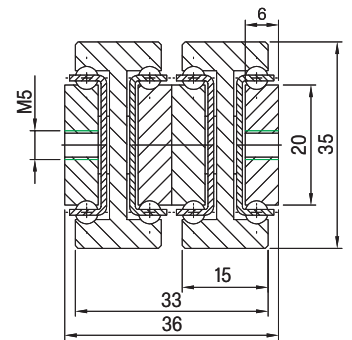
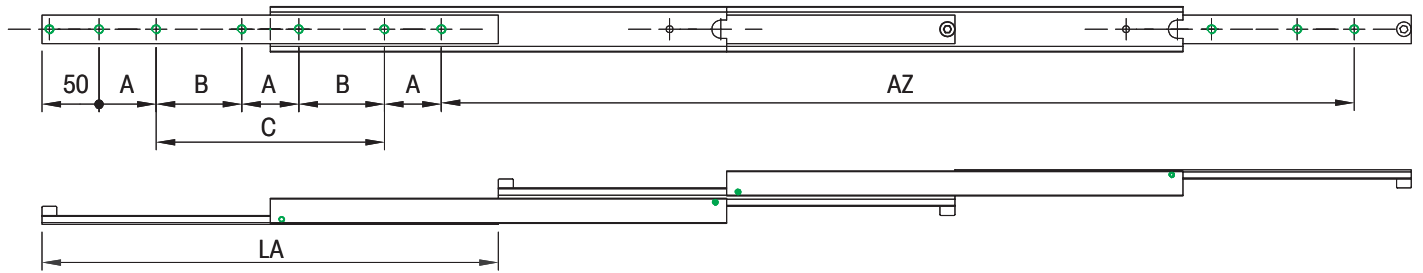

Artikel-Nr. SToxxparts	LA mm	AZ mm	TK in kg 10.000	A mm	B mm	C mm	Gewicht weight kg/St. kg/pcs.
07000474001	150	300	60	50	-	-	1,19
07000474002	200	400	70	50	-	-	1,57
07000474003	250	500	80	50	-	50	1,95
07000474004	300	600	90	50	-	100	2,34
07000474005	350	700	100	50	-	150	2,72
07000474006	400	800	90	50	-	200	3,10
07000474007	450	900	80	50	-	250	3,49
07000474008	500	1000	70	50	-	300	3,87
07000474009	550	1100	65	50	150	-	4,25
07000474010	600	1200	60	50	175	-	4,64
07000474011	650	1300	55	50	200	-	5,02
07000474012	700	1400	50	50	225	-	5,40
07000474013	750	1500	45	50	250	-	5,79
07000474014	800	1600	40	50	275	-	6,17
07000474015	850	1700	35	50	300	-	6,55
07000474016	900	1800	30	50	325	-	6,94
07000474017	950	1900	25	50	350	-	7,32
07000474018	1000	2000	20	50	375	-	7,70

Hinweise | Notes:

LA = Länge | Length, AZ = Auszugsweg | Move-out path, TK = Tragkraft | Load capacity |

Bohrbild / Hole pattern

Die Tragfähigkeit im horizontalem Einbau reduziert sich um 60-80%.

Flat mounted slide load capacities are reduced between 60-80%